

NCb-371

3MP LPR High Speed Box Camera, 1/1.8" Image Sensor, Global Shutter



Main Features

- LPR high speed box camera
- Max. 2048x1536@50fps
- 1/1.8" Sony Pregius sensor
- Global shutter
- Support -10°C ~50°C / 14°F ~ 122°F
- Lens optional

ONVIF



Product Overview

NCb-371 is the next generation Box type NexCam that provides exceptional frame-rate and image clarity, mainly designed for LPR/ANPR applications. The introduction of sophisticated global shutter in the camera used in combination of 1/1.8" Sony Pregius 3MP progressive scan CMOS image sensor, effectively addresses to the problem of conventional CMOS sensor's inability to synchronize with a flash strobe. NCb-371's excellent performance under low light conditions with global shutter, allow users to capture megapixel quality snapshots while monitoring vehicles moving at high speed. This makes NCb-371 ideal for high speed applications such as license plate recognition (LPR) and intelligent transportation system (ITS).

1080P @ 30 fps

In Global Shutter mode, every pixel is exposed simultaneously at the same instant in time, enabling "freeze frame" capture of fast moving or fast changing events. With this feature, NCb-371 deliver image without spatial distortion and enhance the intelligibility when the object over 200km (124miles).

3 Megapixel Resolution @ 50 fps

NCb-371 adopts high-performance H.264/MJPEG compression technology which offers extra smooth video at up to 50fps in 3 megapixel resolution. Furthermore, Video ROI [Region of Interest] function reduce bandwidth and storage requirement, providing users the bandwidth flexibility and storage efficiency that they need.

RICH I/O

NCb-371's rich I/O allows the users to enjoy the benefit of connecting to a variety of essential external devices such as audio jack, micro SD card slot, flash strobe out and IR strobe out in order to achieve best performance for any critical environments. It also includes Digital Input and Digital output for integrated application with an alarm system.

Specifications

Camera General Information

Image Sensor	1/1.8" Sony Pregius CMOS image sensor
Minimum Illumination	B/W 0.01 lux/ Color 0.05 lux, @F1.5
Lens	CS mount/ C mount with adapter
Iris Type	Supports DC & P-Iris*
Day and Night	Yes (With ICR & Light Sensor)
Minimum Exposure Time	1/7 ~ 1/30,000s
Target Capture Plate	Reflective and Non-reflective
Car Speed	250KM/h max.
ICR	YES
Image Setting	Brightness, Contrast, Saturation, Sharpness, Mirror& Flip, Day/Night, Schedule D/N, Hue Adjust,

Video

Video Compression	H.264++/M-JPEG
Video Streaming	Triple Streaming
Video Resolution	2048x1536 to 320x240
Video Quality	VBR/CBR
Frame Rate	2048x1536 @ 50fps 1920x1080 @30fps 1280x720 @30fps 640x480 @30fps 320x240 @30fps

Audio

Audio Streaming	Two-way
Audio Compression	G.711 8KHz/16bit
Audio Input	Line-in
Audio Output	Line-out

Dimension Drawing

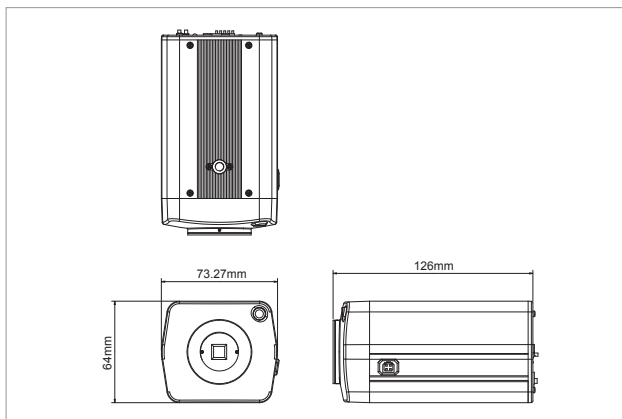

Network

Interface	10/100/1000 Mbps Ethernet, RJ-45
Supported Protocols	HTTP, HTTPS, SSL, TCP/IP, UDP, RTP, RTSP, FTP, SMTP, DHCP, DNS, DDNS, NTP, uPnP, IPv4, IPv6, SNMP, Zero Configure, 802.1x, GB28181
Browser	Internet Explorer, Chrome, Firefox, Safari
Security	Multi-level passwords/HTTP encryption

I/O Connector

Audio in/ out	x2 (3.5mm phone jack)
RS485	x1 (terminal block)(optional)
RS232	x1 (terminal block)(optional)
IR LED strobe out	x1 (terminal block)
DI/DO	DI x2, DO x2
Reset button	x2 (1 for reboot & 1 for factory default)
Power LED	x1 (Red LED)
Micro SD slot	x1

Event Management

Event Trigger	Alarm, Motion detection, Sabotage
Notifications	Trigger alarm output, email/FTP and record Snapshot/video to Network storage or Micro SD card
Post Recording	YES
Pre Recording	YES

Power

DC/AC	DC12V/AC 24V terminal block
POE	YES/IEEE 802.3at

General

Power Consumption	Up to 5W max
Weight	470g
Dimension	126mm (D) x 73.27mm (W) x 64mm (H)
Operating Temp.	-10°C~50°C (14°F - 122°F)
Humidity	10%~90%RH (no condensation)
Certification	CE/FCC class A
Application	SDK available for application development

Packaging Information

NWT	470g
GWT	703g
Dimension	214x129x128mm
Lens	No Lens included

Ordering Information

- **Ncb-371: 3MP Global Shutter Box Camera**
(Support Tamron P-iris Lens, Model No. M118VP413IRCS)
- **Ncb-373: 3MP Global Shutter Box Camera (Support DC-iris Lens)**