



ATC 3530-IP7-4M



ATC 3530-IP7-4C

Main Features

- AI Edge In-vehicle computer
- 4-Ch MIPI SerDes, 1080p60/4Kp30 over 15m cable (ATC 3530-IP7-4M)
- Built-in NVIDIA® Jetson Xavier™ NX SOM, up to 21 TOPS compute
- 4-port GbE PoE+ for IP CAM/LiDAR sensors (ATC 3530-IP7-4C)
- HEVC/H.265 hardware CODEC, 32 x 1080p30 compute power
- Wide range operating temperature of -30~70°C
- The rugged, fanless design with IP67 rating
- Ultra-speed PCIe 3.0 x4 NVMe SSD for data integrity
- NEXCOM Aided Linux (NAL) OS w/ JetPack4.5 integrated
- Expandable for LTE/5G NR & Wi-Fi 5/6
- 9~36V DC-in with ignition control & OCP/OVP
- CE/FCC, UKCA, Emark certified

Product Overview

AI has become an essential component of automated vehicle technologies. With built-in high performance/watt NVIDIA® Jetson Xavier™ NX SOM, ATC 3530 can deliver up to 21 TOPS for running modern AI workloads with consuming 15W low power, suitable for autonomous machines, such as agriculture, construction including mining, heavy truck, to fulfill the target of enhancing the productivity and the lower TCO.

ATC 3530 is a fanless, compact size and IP67 rating design. It features 9~36VDC with IGN control, 4 MIPI CSI-2 with PoC for 15m long reach at 4Kp30/1080p60 or 4 GbE PoE for deploying the IP video sensors. Besides, ATC 3530 is designed to build with diverse peripheral ports, GbE/PoE, USB 3.0/2.0, isolation CAN, RS232, Console, DI/DO, OTG and HDMI.

To advance to edge computing collaborated with CSP, the users have to install the 5G NR, Wi-Fi 5/6 modules and ultra-speed PCIe 3.0 x4 NVMe SSD easily and quickly. To sustain to the harsh in-vehicle applications, ATC 3530 can operate at a wide temperature range of -30~70°C and meet MIL-STD-810G military standard at vibration and shock. For the regulation, ATC 3530 is compliant with CE/FCC classA, UKCA and Emark (E13).

Specifications

NVIDIA® Jetson Xavier™ NX SOM

- 3 x NVIDIA® 64-bit Carmel (Dual-Core) processor, 1900 MHz
- 384-Core Volta & 48-core Tensor integrated, 1100MHz
- 6 TFOPS (FP16), 21 TOPS (INT8) compute
- OpenGL 4.6, OpenGL ES 3.2, and Vulkan 1.1
- 260-Pin SO-DIMM form factor compatible with NANO/TX2 NX
- NVIDIA® JetPack4.5

Memory

- 8GB 128-bit LPDDR4, 1600MHz

Storage

- 16GB eMMC 5.1 flash storage, 200 MHz (HS400)
- 1 x Accessible microSD (SDXC, UHS-I)
- 1 x M.2 2280/3080 Key M PCIe 3.0 x4 NVMe SSD

Expansion

- 1 x Full size mPCIe socket (PCIe 3.0 + USB 2.0)
- 1 x M.2 3042/3052 Key B socket (USB 3.0) with 2 x micro SIM slots

Display

- 1 x HDMI 2.0A/B, up to 3840 x 2160@60Hz

G-Sensor

- 3D accelerometer and 3D gyroscope, ST LSM6DSLTR

GbE

- 1-Port GbE, X-coded (ATC 3530-IP7-4C)
- 2-Port GbE, X-coded (ATC 3530-IP7-4M)
- 9Kbyte Jumbo frame, PTP (IEEE 1588) support
- Controller: Intel® I210-IT

PoE (only for ATC 3530-IP7-4C)

- 4-Port Gbps, X-coded
- IEEE 802.3af/at compliant
- 30W (4-port) power budget in total
- PoE on/off and power watt monitoring

MIPI CSI-2 SerDes (only for ATC 3530-IP7-4M)

- Up to 4 x individual channel (1080p60/720p30 resolution)
- Thine SerDes solution (V-by-One® HS)
- Integrated with 3rd party MIPI SerDes camera (IP67 rating)
 - 1080p60 CAM: CAM1-MT1080-IP7-15m
 - 720p30 CAM: CAM1-MT720-IP7-15m

USB

- 2 x USB 3.0 (USB 3.2 Gen1), type A
 - 5V@900mA each
 - up to 5Gbit/s link speed & compliance with USB 2.0 (LS/FS/HS link speed)
- 1 x OTG micro USB

Serial Port

- 1 x RS232 (Tx, Rx, CTS, RTS)
- 1 x RS232 (Tx, Rx)
- 1 x Console port (Tx, Rx)
- RS232 working voltage, ±9V, baud rate up to 115.2kb/s

DI/DO (reserved)

- 4-Bit input
 - Source: 9~36VDC (12V@0.6mA/24V@1.2mA)
 - External: 0~33VDC pull-high, high-level, 3.3 - 33VDC; low-level, 0-2 VDC

Dimension Drawing

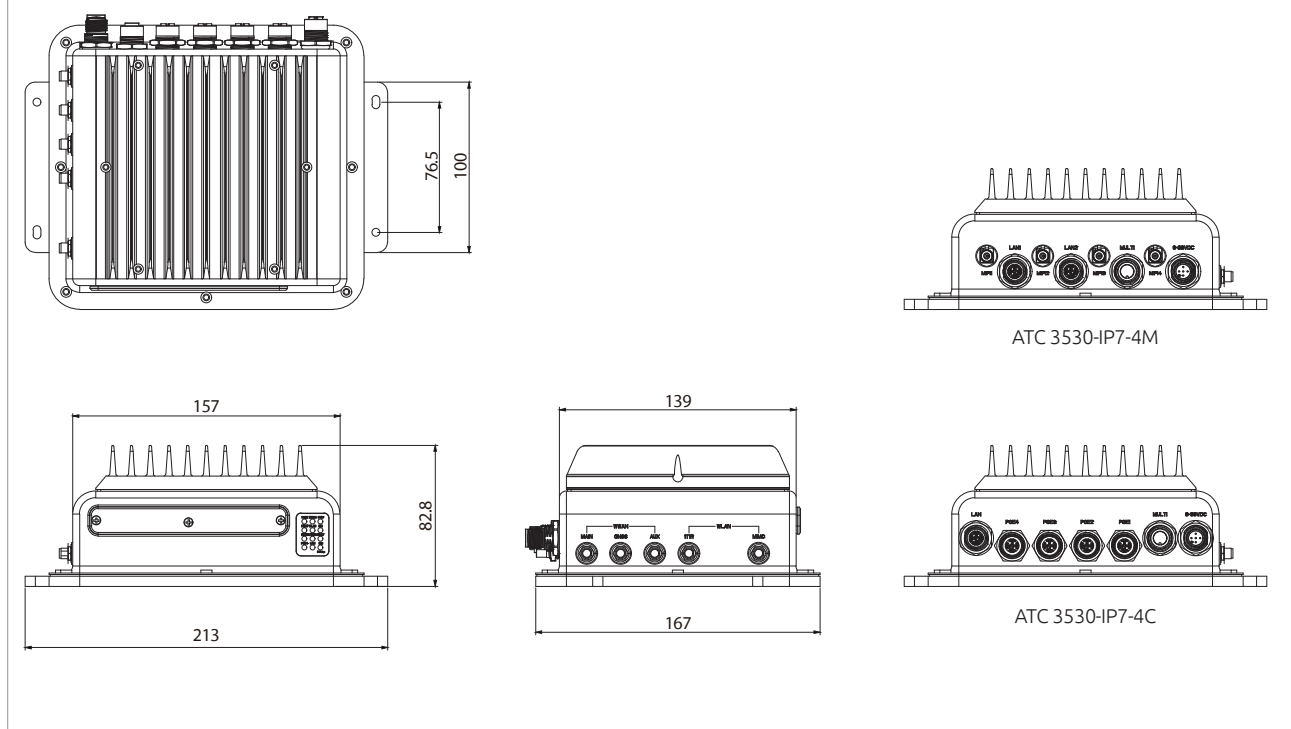

- 4-Bit output
 - Source: 9~36VDC (nominal 35mA@24V)
 - External: 5~27VDC pull-high, sink current w/ 220mA for each bit, 500mA max (@25C)
- Source or external can be selected by software (default: source type)

CAN Bus

- 1 x CAN 2.0A/2.0B
- IEC 61000-4-2 Electrostatic Discharge (ESD): ±8KV/15KV (contact/air)
- 2.5KV isolated

GPS

- U-blox NEO-M8N GNSS module for GPS/Glonass/QZSS/Galileo/Beidou
- Optional DR (dead reckoning) function, NEO-M8U/M8L

Power Supply

- Nominal voltage: 9~36V
- Cranking voltage: 6V~9V (less than 20 sec)
- OCP & UVP (shut down once exceeding 37V)
- Ignition on/off control & programmable on/off delay timer
- Opional for remote power on/off control

I/O Ports, Front-Plate

- 12 x LED indicators
- Reset button, 1 x microSD slot, 1 x OTG
- 2 x Micro SIM slots, 1 x HDMI, 2 x USB 3.0

I/O Ports, Rear-Plate

- 9~36VDC-in, S-coded
- 4 x Fakra z-code & 2 x GbE, X-coded (ATC 3530-IP7-4M)
- 4 x GbE PoE & 1 x GbE, X-coded (ATC 3530-IP7-4C)
- M12 multi-port (2 x RS232 & 1 x console, 1 x CAN)

I/O Ports, Side-Plate

- 2 x antenna holes for Wi-Fi 5/6 modules (PR-SMA ant.)
- 2 x antenna holes for LTE/5G module (SMA ant.)
- 1 x antenna hole for GNSS (RP-SMA ant.)

Dimensions & Weight

- 213mm x 167mm x 82.8mm (w/ mount bracket)
- 2.4kg

Environment

- Operating temperatures: -30°C~70°C (70°C: NVIDIA® Jetson Xavier™ NX@10W, w/o PoE; 60°C: NVIDIA® Jetson Xavier™ NX@15W w/ 30W PoE)

- Storage temperatures: -40°C~85°C
- Relative humidity: 10%~95% (non-condensing)

Vibration & Shock

- Vibration in operating
 - MIL-STD-810G, 514.6C, Procedure 3, Category 4
 - IEC 60068-2-64: 2.0g@5~500 Hz
 - MIL-STD-810G, 514.6E, Procedure 1, Category 24, 7.7g approx.
- Shock
 - Operating: MIL-STD-810G, Method 516.6, Procedure I, functional shock=20g
 - Non-operating: MIL-STD-810G, Method 516.6, Procedure V, crash hazard shock test=75g

Certifications

- CE approval, FCC Class A, UKCA, E13 certified

Operating System

- NEXCOM Aided Linux (NAL)
 - NV Jetpack 4.5 package
 - MIPI SerDes CAM Driver
 - NEXCOM custom functions (GNSS, 5G NR, 6-axis sensor, MCU control)
 - V4L2
 - Ubuntu 18.04 @Kernel 4.9.140

External Cable

- Power extension cable, 20cm
- M12 multi-port adapter cable, 20cm

Ordering Information

- **ATC 3530-IP7-4C (P/N: 10AT0353001X0)**
IP67 rating AI edge compute, NVIDIA® Jetson Xavier™ NX SOM, 8GB LPDDR4, 16GB eMMC, 4 x GbE PoE, 1 x GbE, 2 x RS232, 2 x USB 3.0
- **ATC 3530-IP7-4M (P/N: 10AT0353000X0)**
IP67 rating AI edge compute, NVIDIA® Jetson Xavier™ NX SOM, 8GB LPDDR4, 16GB eMMC, 4 x MIPI VBO, 2 x GbE, 2 x RS232, 2 x USB 3.0
- **CAM1-MT1080-IP7-15m (P/N: 10AT0108001X0)**
IP67 rating MIPI VBO SerDes CAM, 1080p60, AP-AR0234GSC-ISP-S-SerDes, 15m
- **CAM1-MT720-IP7-15m (P/N: 10AT0072001X0)**
IP67 rating MIPI VBO SerDes CAM, 720p30, AP-AR0144GSC-ISP-S-SerDes 15m