

EN 50155 Managed Gigabit Routing Switch Viper-8 Series

- Compact and powerful routing switch approved for rolling stock
 - Full speed routing capability
 - 8 x 1 Gbps ports
 - Single model 24-110 VDC ($\pm 30\%$) power range
- Designed and built for extreme operational environments
 - Robustness-enhancing design features
 - Extensive range of approvals, by IEC/ISO 17025 certified laboratories
 - Quality-focused engineering and production located in Sweden
- Powered by WeOS, Westermo's proven network operating system
 - High level cyber security
 - Easy to use

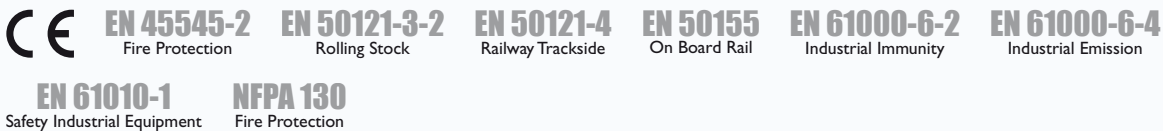

The Viper-8 series is a managed backbone routing switch optimised for the needs of the railway rolling stock market. High speed Gbps ports and full speed routing capability cope with high bandwidth backbone, consist ring and end-devices.

The Viper-8 series is designed to withstand the tough environment on-board trains, exposing the switch to constant vibration, extreme temperatures, humidity and a demanding electrical environment.

A GORE-TEX® membrane prevents internal condensation. Threading integrated in chassis provides for additional vibration resistance. High-level isolation between all interfaces enables direct connectivity to vehicle auxiliary power and protects against overvoltage and flashover. IP67 protection prevents ingress of water and dust. An overall optimised design results in an extremely compact package in combination with very high MTBF for easy integration and low lifecycle cost.

Thorough type testing at independent ISO/IEC 17025 and ILAC MRA certified labs, accredited to a wide range of standards, show that the Viper-8 series fulfills EN 50155 and other requirements. The state-of-the-art Westermo production facility ensures the quality of each individual unit, e.g. through temperature cycling burn-in testing.

The WeOS operating system offers an extensive suite of IP networking features for resilient and flexible networks, e.g. the FRNT ring protocol with very fast failover. The powerful layer 3 routing capability ensures communication between the backbone and consist networks. The backup device accessory matches the Viper in robustness and offers easy configuration update and backup.

Specifications - Viper-8 series

Dimensional drawing

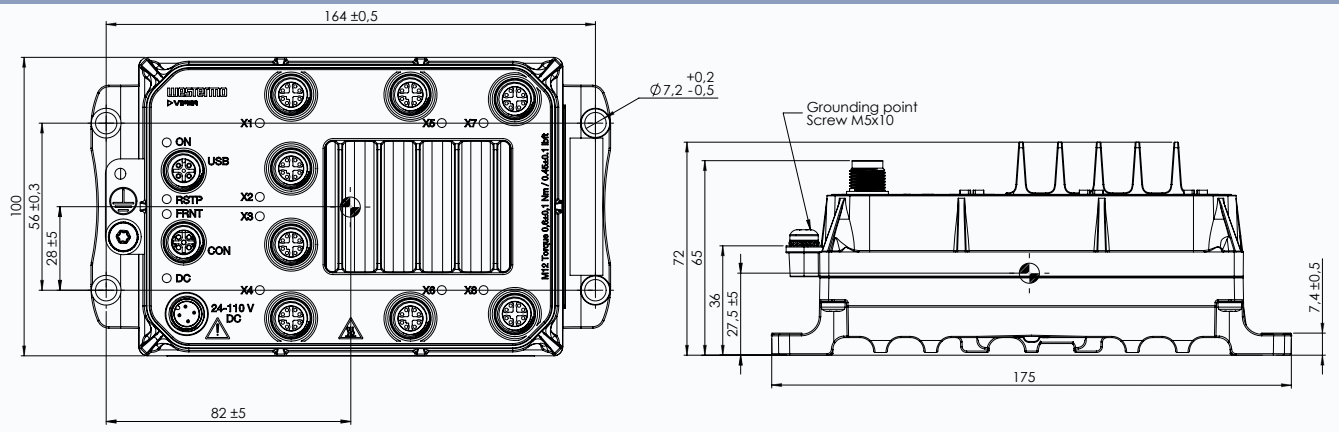

Technical data

Dimensions (W x H x D)	175 x 100 x 72 mm (6.89 x 3.94 x 2.85 inches)
Weight	1.5 kg
Housing	Full metal
Rated voltage	24 to 110 VDC
Operating voltage	16.8 to 143 VDC (14.4 to 154 VDC for 100 ms)
Rated current	Max 460 mA at 24 VDC, max 110 mA at 110 VDC
Power interruption	Class S2 (10 ms hold-up) according to EN50155
Operating temperature	-40 to +70°C (-40 to +158°F) (+85°C for a limited time)
Storage and transport temperatures	-55 to +85°C (-67 to +185°F)
Ingress protection	IP66 and IP67
Humidity (operating)	5-95% relative humidity, operational, storage and transport
Altitude	2000 m/80 kPa

Interface

Ethernet 1 Gbps (X-coded)	8
Backup and restore port	1
Console port (RS-232, B-coded)	1

MTBF

MIL-HDBK-217F-N2, GB, +25°C/+77°F	659.000 h
IEC 62380	603.000 h

Type	Approval/Compliance
Climate	<ul style="list-style-type: none"> EN 50155 class OT4/IEC 60571 class TX, Railway applications - Electronic equipment used on rolling stock, Rapid temperature variations class H2 IEEE 1478 class 1, condition E4 (incl Salt Mist), Environmental conditions for transit rail car electronic equipment
EMC	<ul style="list-style-type: none"> EN/IEC 61000-6-2, Immunity industrial environments EN/IEC 61000-6-4, Emission industrial environments EN 50121-4/IEC 62236-4, Railway signalling and telecommunications apparatus EN 50121-3-2/IEC 62236-3-2 Railway applications – Rolling stock – apparatus Tested and verified for Class S1, DB EMC Regulation 06, Commodity team Radio compatibility in VDB Rev 1.0 (Shunting Radio) Tested and verified for FCC part 15
Mechanical (Shock and vibration)	<ul style="list-style-type: none"> EN 61373 category 1, class A and B IEEE 1478 class 1, condition E4, including shock tests 10 g/30 ms and 20 g/11 ms in all directions
Insulation (Coordination and test)	<ul style="list-style-type: none"> EN 50124-1, Railway applications – Insulation coordination EN 50155/IEC 60571, Railway applications - Electronic equipment used on rolling stock
Fire protection	<ul style="list-style-type: none"> EN 45545-2, Fire protection on railway vehicles NFPA 130, Fire protection for fixed guideway transit and passenger rail system
Safety	<ul style="list-style-type: none"> EN/IEC/UL 61010-1, -2-201, Safety requirements for electrical equipment for measurement, control, and laboratory use
Software	<ul style="list-style-type: none"> EN 50657:2017 Software Onboard Rolling Stock (Basic Integrity)

Software	
WeOS	WeOS 5; https://www.westermo.com/solutions/weos
WeConfig	https://www.westermo.com/solutions/weconfig

Warranty	
Validity	5 years

Art.no.	Product	Functionality
3635-2210	Viper-108-T8G	Layer 2
3635-2220	Viper-208-T8G	Layer 3

Accessories	
3641-0190	M12 USB configuration backup device
3641-7190	M12 USB configuration backup device with attachment strap
3146-11xx	Patch and power cables, see www.westermo.com
1211-4073	Console cable
WeConfig	https://www.westermo.com/products/software/weconfig

Specification WeOS 5

The WeOS operating system has been developed by Westermo for its current as well as future range of Ethernet hardware products. This layer 2 and layer 3 switching solution enables Westermo to create complex multimedia ring networks and routing solutions. WeOS not only provides solutions to many challenging industrial networking issues, but also helps to protect investments by ensuring the future availability of fully compatible solutions. WeOS is the core of our latest ranges of Ethernet hardware allowing complex multimedia ring networks and routing solutions to be created.

Westermo has many years of experience developing products for industrial applications. At the heart of all Westermo networking solutions is the need for ease of use. By standardising on a single operating system for all Westermo Ethernet products this helps to simplify the installation, operation and maintenance of individual devices and complete networks. Once a user is familiar with a Westermo product, that knowledge can be readily applied to all our other devices. A web screen simplifies the configuration of many functions, whilst a command line interface allows for fine tuning.

WeOS Standard - Layer 2 protocols and functionality
Resilience and High Availability FRNTv0 ring topologies (rings, ring coupling and horseshoe topologies), IEEE 802.1D/802.1w (RSTP), IEEE 802.1AX/802.3ad Link Aggregation (LACP and Static), IEC 62439-2 Media Redundancy Protocol (MRP; single instance or dual instances at MRP master) ^a
Layer 2 Switching IEEE 802.1D MAC Bridges, IEEE 802.1Q Static VLAN and VLAN Tagging, IEEE 802.1AB LLDP, IGMPv1/v2/v3 Snooping, Static Multicast MAC filters
Layer 2 QoS IEEE 802.1p Class of Service with flexible classification (VLAN tag priority, IP DSCP/ToS, Port ID), Ingress and Egress Rate limiting
IP Host Services Static IP Address, DHCP Client, DNS Client, DDNS, ZeroConf (mDNS and SSDP), NTP Client (NTPv4), IP Interfaces (Ethernet, VLAN, Loopback and Blackhole)
Network Servers DHCP Server (including options 1, 3, 6, 7, 12, 15, 42, 61 and 82), DHCP Relay Agent (including options 54 and 82), DNS Proxy Server (DNS forwarder and Host records), NTP server (NTPv4)
Management Tools Westermo configuration tool WeConfig, Web interface (HTTP and HTTPS), Command Line Interface (CLI) via console port, SSHv2 and Telnet, Local and Central Authentication (RADIUS/TACACS+), Role Based Access Control (RBAC), Password Compliance Policy, SNMPv1/v2c/v3, Secure Copy (SCP) for remote file upload and download, Local file management (via HTTP, FTP, TFTP and SCP), Load/save files from/to external memory, Configuration and Deployment using external memory, Tech support button, Flexible alarm and event handling system, RFC5424/RFC3164 Syslog (log files and remote syslog server), Port monitoring
SNMP MIB Support (read-only) RFC 1213 MIB-2, RFC 2819 RMON MIB, RFC 2863 Interface MIB, RFC 3433 Entity Sensor MIB, RFC 3635 Ether-like Interface MIB, RFC 4133 Entity MIB, RFC 4188 Bridge MIB, RFC 4318 RSTP MIB, RFC4363 Q-BRIDGE MIB, RFC 4836 MAU MIB, IEEE 802.1AB LLDP MIB, IEEE 802.1AX LAG MIB, IEC 62439-2 MRP MIB, WESTERMO-DDM MIB (SFP), WESTERMO-EVENT MIB, WESTERMO-FRNT MIB, WESTERMO-INTERFACE MIB, WESTERMO-TCN MIB

^aAvailable as add-on-function. Please see your local Westermo sales contact to purchase a license for your product.

WeOS Extended - Layer 3 protocols and functionality ^a
IP Host Services IP Interfaces (SSL, VPN, GRE)
IP Routing and VPN Static IP Routing, Floating Static Routes, Multinetting, Proxy ARP, Dynamic IP routing (OSPFv2, RIPv1/v2), VRRPv2/v3, Static Multicast Routing, Stateful Inspection Firewall, Firewall Hit Counters, IP Masquerading (NAT/NAPT), Port Forwarding, Stateless NAT (1-1 NAT), SSL VPN (Client and Server, Certificate Authentication, Pre-shared Key (PSK) Point-to-Point Mode, Layer-2 and Layer-3 VPN, Layer-2 VPN bridging, Address pool and address per CN, TLS Authentication), Generic Routing Encapsulation (GRE)
SNMP MIB Support (read-only) RFC 2787 VRRPv2 MIB, RFC 6527 VRRPv3 MIB

^aProducts with software level WeOS Extended include all functionality listed for WeOS Standard